

## FEATURES

- Digital output
- Effective Range: 10 to 80 cm
- LED pulse cycle duration: 32 ms
- Factory set trigger point: 24°
- Typical response time: 39 ms
- Typical start up delay: 46 ms
- Average current consumption: 33 mA
- Detection area diameter @ 80 cm: 6 cm

## DESCRIPTION

The GP2D15 is a distance measuring sensor with integrated signal processing and digital output.

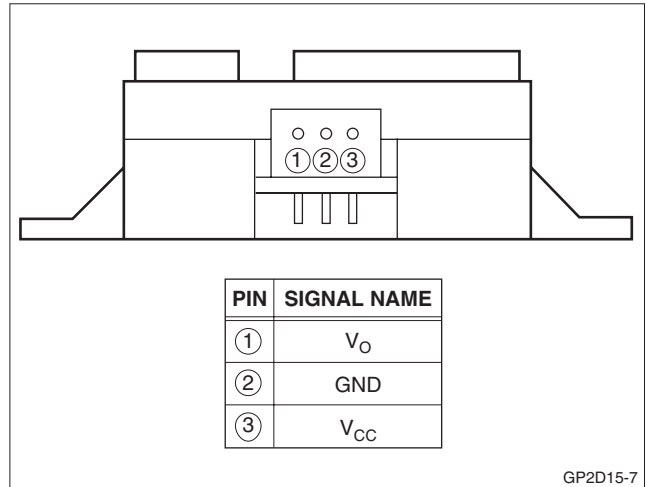

Figure 1. Pinout

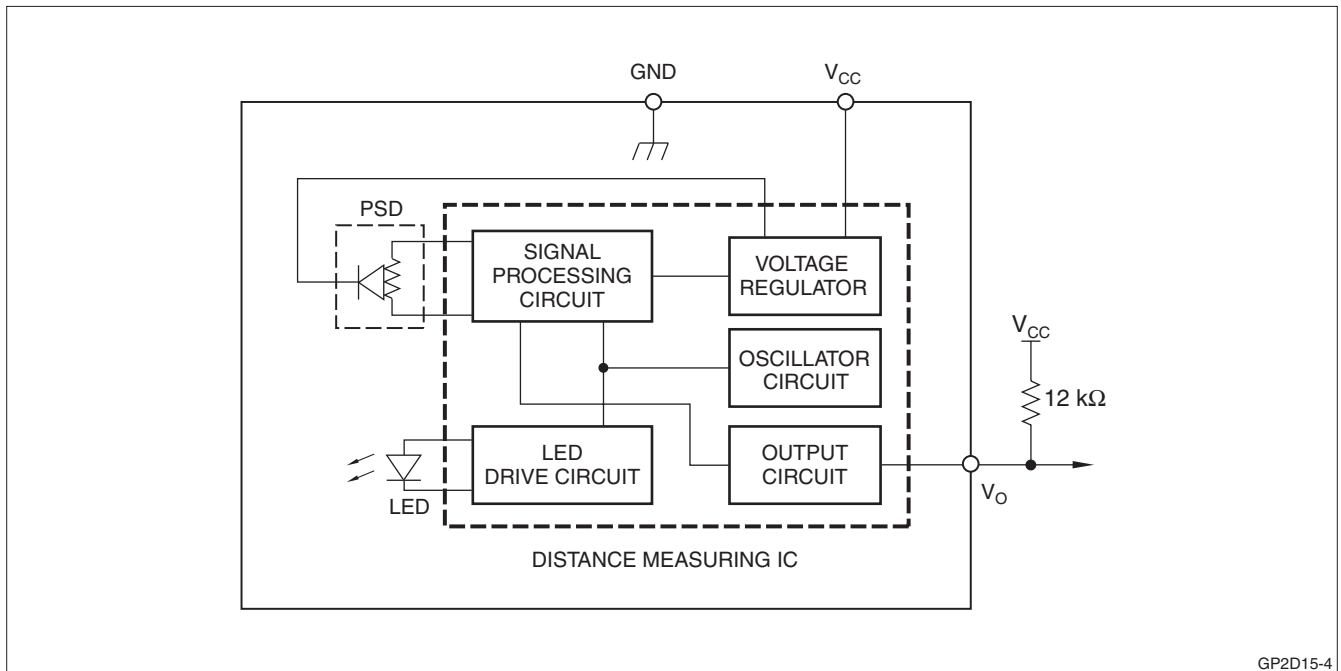

Figure 2. Block Diagram

**ELECTRICAL SPECIFICATIONS****Absolute Maximum Ratings**

$T_a = 25^\circ\text{C}$ ,  $V_{CC} = 5\text{ VDC}$

PARAMETER	SYMBOL	RATING	UNIT	REMARKS
Supply Voltage	$V_{CC}$	-0.3 to +7	V	
Output Terminal Voltage	$V_O$	-0.3 to ( $V_{CC} + 0.3$ )	V	Open collector output
Operating Temperature	$T_{opr}$	-10 to +60	$^\circ\text{C}$	
Storage Temperature	$T_{stg}$	-40 to +70	$^\circ\text{C}$	

**Operating Supply Voltage**

PARAMETER	SYMBOL	RATING	UNIT
Operating Supply Voltage	$V_{CC}$	4.5 to 5.5	V

**Electro-optical Characteristics**

$T_a = 25^\circ\text{C}$ ,  $V_{CC} = 5\text{ VDC}$

PARAMETER	SYMBOL	CONDITIONS	MIN.	TYP.	MAX.	UNIT	NOTES
Measuring Distance Range	$\Delta L$		10	—	80	cm	1, 3
Output Terminal Voltage	$V_{OH}$	Output voltage at high level	$V_{CC} - 0.3$	—	—	V	1
	$V_{OL}$	Output voltage at low level	—	—	0.6	V	1
Output Distance Characteristics	$V_O$		21	24	27	cm	1, 2, 4
Average Supply Current	$I_{CC}$		—	33	50	mA	

**NOTES:**

1. Measurements made with Kodak R-27 Gray Card, using the white side, (90% reflectivity).
2. L = Distance to reflective object.
3. Factory set to detect at  $L = 24\text{ cm} \pm 3\text{ cm}$ .
4. Distance measuring range of the sensor optics.
5. Output switching has hysteresis. The distance specified by  $V_O$  is for LOW to HIGH switching.

## RELIABILITY

The reliability of requirements of this device are listed in Table 1.

**Table 1. Reliability**

TEST ITEMS	TEST CONDITIONS	FAILURE JUDGEMENT CRITERIA	SAMPLES (n), DEFECTIVE (C)
Temperature Cycling	One cycle -40°C (30 min.) to +70°C in 30 minutes, repeated 25 times	Initial $\times 0.8 > V_O$ $V_O > \text{Initial} \times 1.2$	n = 11, C = 0
High Temperature and High Humidity Storage	+40°C, 90% RH, 500h		n = 11, C = 0
High Temperature Storage	+70°C, 500h		n = 11, C = 0
Low Temperature Storage	-40°C, 500h		n = 11, C = 0
Operation Life (High Temperature)	+60°C, $V_{CC} = 5\text{ V}$ , 500h		n = 11, C = 0
Mechanical Shock	100 m/s <sup>2</sup> , 6.0 ms 3 times/ $\pm X$ , $\pm Y$ , $\pm Z$ direction		n = 6, C = 0
Variable Frequency Vibration	10-to-55-to-10 Hz in 1 minute Amplitude: 1.5 mm 2h in each X, Y, Z direction		n = 6, C = 0

### NOTES:

1. Test conditions are according to Electro-optical Characteristics, shown on page 2.
2. At completion of the test, allow device to remain at nominal room temperature and humidity (non-condensing) for two hours.
3. Confidence level: 90%, Lot Tolerance Percent Defect (LTPD): 20%/40%.

## MANUFACTURER'S INSPECTION

### Inspection Lot

Inspection shall be carried out per each delivery lot.

### Inspection Method

A single sampling plan, normal inspection level II based on ISO 2859 shall be adopted.

**Table 2. Quality Level**

DEFECT	INSPECTION ITEM/TEST METHOD	AQL (%)
Major Defect	Electro-optical characteristics defect	0.4
Minor Defect	Defect on appearance and dimension (crack, split, chip, scratch, stain)*	1.0

**NOTE:** \*Any one of these that affects the Electro-optical Characteristics shall be considered a defect.

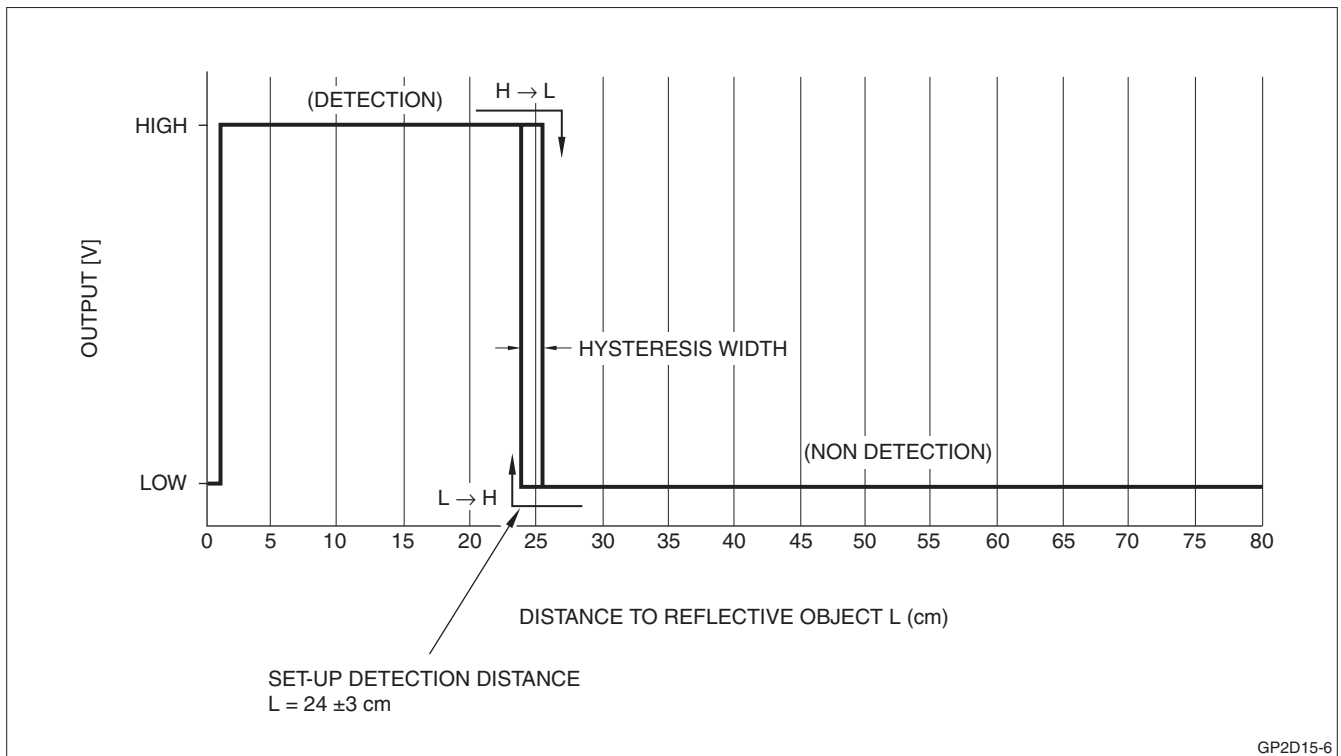
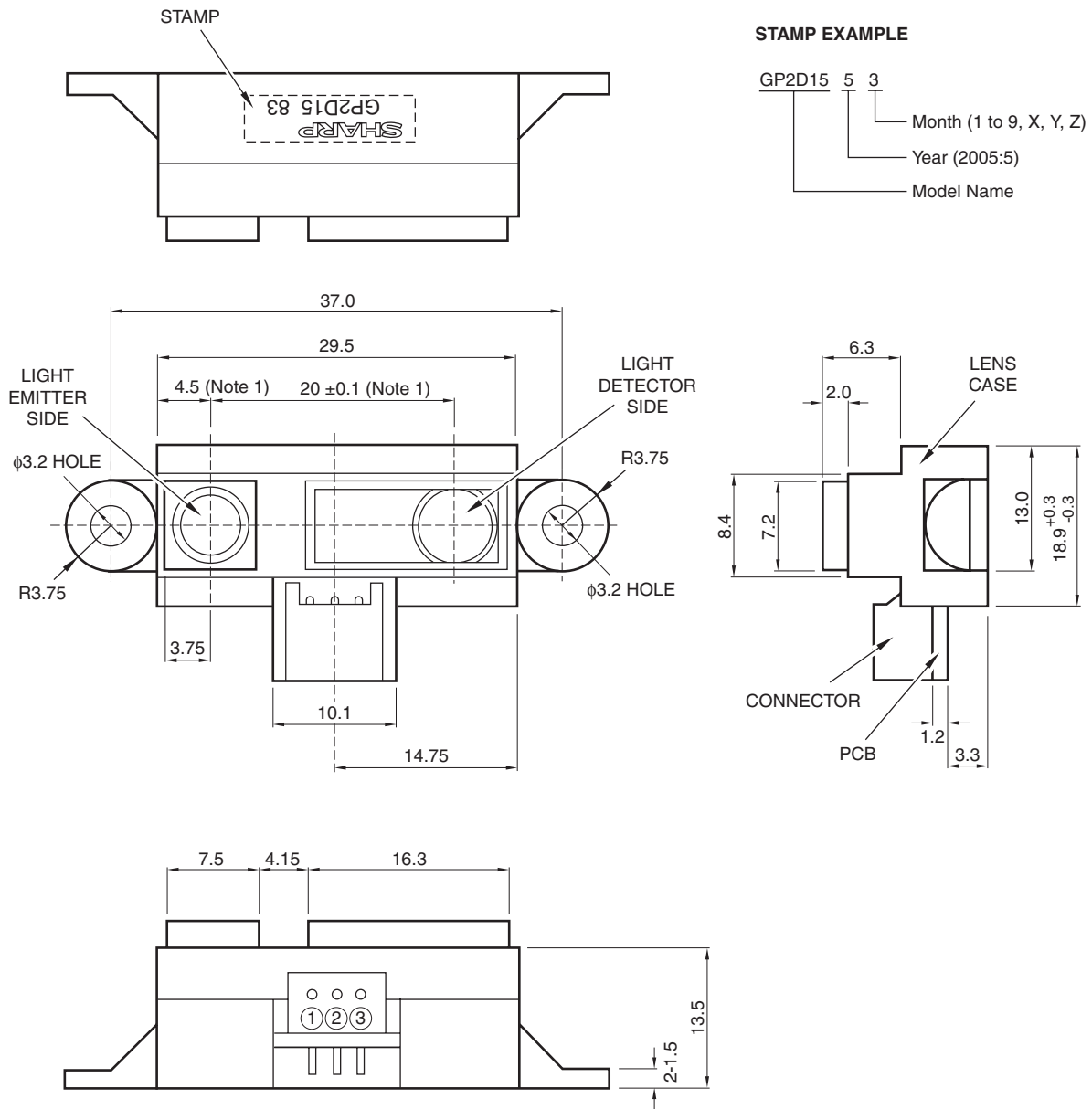
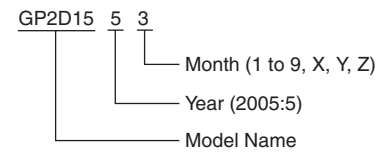

Figure 3. GP2D15 Example of Output Distance Characteristics

PACKAGE SPECIFICATIONS



STAMP EXAMPLE



CONNECTOR SIGNAL

PIN	SIGNAL NAME
①	V <sub>O</sub>
②	GND
③	V <sub>CC</sub>

Connector: J.S.T. Trading Company, LTD  
S3B-PH

NOTES:

- Dimensions shall reference lens center.
- Unspecified tolerance shall be ±0.3 mm.
- Scale: 2/1, dimensions are in mm.

GP2D15-3

PACKING SPECIFICATION

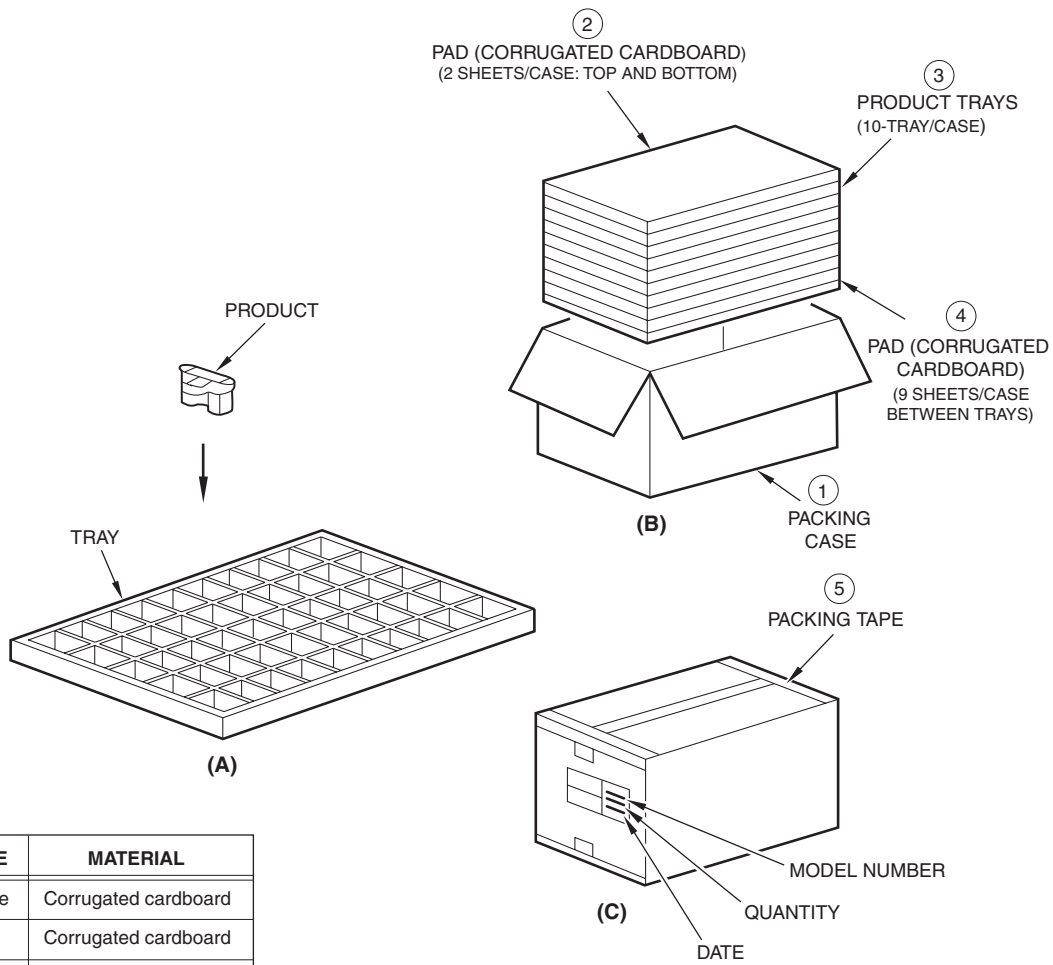

PART NAME	MATERIAL
Packing case	Corrugated cardboard
Pad	Corrugated cardboard
Tray	Polystyrene

**PACKING METHOD**

1. Each tray holds 50 pieces. Packing methods are shown in (A).
2. Each box holds 10 trays. Pads are added to top and bottom, and between layers, as in (B). top and bottom. Put pads between each tray (9 pads total) see above drawing (B).
3. The box is sealed with craft tape. (C) shows the location of the Model number, Quantity, and Inspection date.
4. Package weight: Approximately 4 kg.

GP2D15-8

## NOTES

- Keep the sensor lens clean. Dust, water, oil, and other contaminants can deteriorate the characteristics of this device. Applications should be designed to eliminate sources of lens contamination.
- When using a protective cover over the emitter and detector, ensure the cover efficiently transmits light throughout the wavelength range of the LED ( $\lambda = 850 \text{ nm} \pm 70 \text{ nm}$ ). Both sides of the protective cover should be highly polished. Use of a protective cover may decrease the effective distance over which the sensor operates. Ensure that any cover does not negatively affect the operation over the intended application range.
- Objects in proximity to the sensor may cause reflections that can affect the operation of the sensor.
- Sources of high ambient light (the sun or strong artificial light) may affect measurement. For best results, the application should be designed to prevent interference from direct sunlight or artificial light.
- Using the sensor with a mirror can induce measurement errors. Often, changing the incident angle on the mirror can correct this problem.
- If a prominent boundary line exists in the surface being measured, it should be aligned vertically to avoid measurement error. See Figure 4 for further details.
- When measuring the distance to objects in motion, align the sensor so that the motion is in the horizontal direction instead of vertical. Figure 5 illustrates the preferred alignment.
- A 10  $\mu\text{F}$  (or larger) bypass capacitor between  $V_{CC}$  and GND near the sensor is recommended.
- To clean the sensor, use a dry cloth. Use of any liquid to clean the device may result in decreased sensitivity or complete failure.
- Excessive mechanical stress can damage the internal sensor or lens.

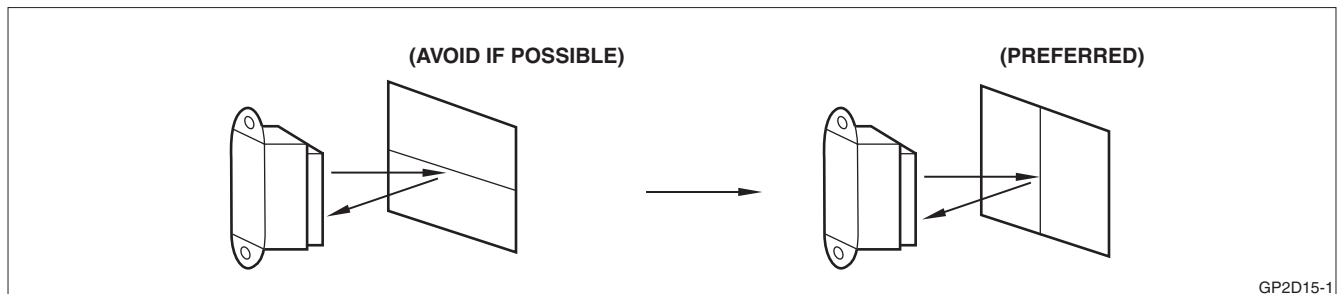

Figure 4. Proper Alignment to Surface Being Measured

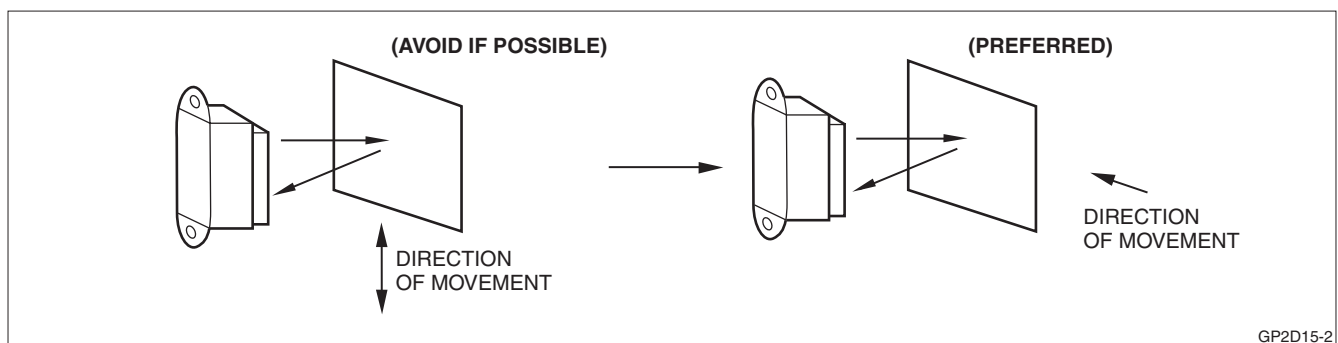

Figure 5. Proper Alignment to Moving Surfaces

**NOTICE**

The circuit application examples in this publication are provided to explain representative applications of SHARP devices and are not intended to guarantee any circuit design or license any intellectual property right. SHARP takes no responsibility for any problems related to any intellectual property right of a third party resulting from the use of SHARP devices.

SHARP reserves the right to make changes in the specifications, characteristics, data, materials, structures and other contents described herein at any time without notice in order to improve design or reliability.

Contact SHARP in order to obtain the latest device specification sheets before using any SHARP device. Manufacturing locations are also subject to change without notice.

In the absence of confirmation by device specification sheets, SHARP takes no responsibility for any defects that occur in equipment using any SHARP devices shown in catalogs, data books, etc.

The devices listed in this publication are designed for standard applications for use in general electronic equipment. SHARP's devices shall not be used for or in connection with equipment that requires an extremely high level of reliability, such as military and aerospace applications, telecommunication equipment (trunk lines), nuclear power control equipment and medical or other life support equipment (e.g. Scuba). SHARP takes no responsibility for damage caused by improper use of device, which does not meet the conditions for use specified in the relevant specification sheet.

If the SHARP devices listed in the publication fall within the scope of strategic products described in the Foreign Exchange and Foreign Trade Law of Japan, it is necessary to obtain approval to export such SHARP devices.

This publication is the proprietary product of SHARP and is copyrighted, with all rights reserved. Under the copyright laws, no part of this publication may be reproduced or transmitted in any form or by any means, electronic or mechanical for any purpose, in whole or in part, without the express written permission of SHARP. Express written permission is also required before any use of this publication may be made by a third party.

Contact and consult with a SHARP representative if there are any questions about the contents of this publication.

---



# SHARP

SHARP CORPORATION  
SALES & MARKETING GROUP  
ELECTRONIC COMPONENTS & DEVICES  
22-22 NAGAIKE-CHO, ABENO-KU, OSAKA 545-8522, JAPAN  
PHONE: (81) 6-6621-1221  
FAX: (81) 6117-725300, 6117-725301, 6117-725302  
<http://sharp-world.com/products/device>

Specifications are subject to change without notice.

## Countries and Areas

### U.S.A.

SHARP MICROELECTRONICS  
OF THE AMERICAS

**North American Head Office**  
5700 North West Pacific Rim Boulevard  
Camas, Washington 98607 USA  
PHONE: (1)360-834-2500  
FAX: (1)360-834-8903  
<http://www.sharpsma.com>

#### Western Area

1980 Zanker Road, San Jose, CA 95112  
PHONE: (1)408-436-4900  
FAX: (1)408-436-0924

5901 Bolsa Ave.  
Huntington Beach, CA 92647-2053  
PHONE: (1)714-903-4600  
FAX: (1)714-903-0295

6390 Greenwich Drive, Suite 175  
San Diego, CA 92122  
PHONE: (1)858-597-0982  
FAX: (1)858-597-8701

#### Central Area

85 W. Algonquin Road, Suite 280  
Arlington Heights, IL 60005  
PHONE: (1)847-258-2750  
FAX: (1)847-439-2479

6303 Commerce Drive, Suite 175 Irving, TX 75063  
PHONE: (1)972-582-1710  
FAX: (1)972-580-7537

8911 Capitol of Texas Hwy. Suite 3130  
Austin, TX 78759  
PHONE: (1)512-349-7262  
FAX: (1)512-349-7002

20333 State Hwy. 249, Suite 200 Houston, TX 77070  
PHONE: (1)281-378-1520  
FAX: (1)281-378-1521

W129 S 9647 Tony Lema Lane Muskego, WI 53150  
PHONE: (1)414-529-9568  
FAX: (1)414-529-9569

3001 West Big Beaver Road, Suite 722  
Troy, MI 48064  
PHONE: (1)248-458-1527  
FAX: (1)248-458-6255

#### Eastern Area

1070 N. Kimbles Road, Yardley, PA 19067  
PHONE: (1)215-321-5530  
FAX: (1)215-321-5534

200 Wheeler Rd., Burlington, MA 01803  
PHONE: (1)781-270-7979; (1)781-229-5100  
FAX: (1)781-229-9117

8000 Regency Parkway, Suite 280 Cary, NC 27511  
PHONE: (1)919-460-0695  
FAX: (1)919-460-0795

2321 Sidney St. Pittsburgh, PA 15203  
PHONE: (1)412-381-1191  
FAX: (1)412-381-1192

4875 North Federal Highway, Third Floor  
Ft. Lauderdale, FL 33318  
PHONE: (1)954-267-8883  
FAX: (1)954-267-0254

### EUROPE

SHARP MICROELECTRONICS EUROPE  
A division of Sharp Electronics (Europe) GmbH

**Head Office**  
Sonninstrasse 3, 20097, Hamburg, Germany  
PHONE: (49)180-5073507  
FAX: (49)40-2376-2232  
<http://www.sharpsme.com/>

#### Germany

SME München Office  
Fuerstenriederstrasse 5, 80687 München, Germany  
PHONE: (49)89-5468420  
FAX: (49)89-54 684250

#### France

SME Paris Office  
1 Rue Raoul Follereau Bussy Saint Georges  
77608 Marne la Vallee Cedex 3  
PHONE: (33)1 6476 22 22  
FAX: (33)1 6476 22 23

#### Italy

SME Milano Office  
Centro Direzionale Colleoni  
Palazzo Taurus Ingresso 2  
20041 Agrate Brianza, Milano, Italy  
PHONE: (390)39-68 99 946  
FAX: (390)39-68 99 948

#### U.K .

SME London Office  
Centennial Court, Easthampstead Road,  
Bracknell, Berkshire R G12 1YQ, United Kingdom  
PHONE: (44)1344-86 99 22  
FAX: (44)1344-36 09 03

#### Ireland

SME Dublin Office  
First Floor, Block 1, St. Johns Court, Santry,  
Dublin 9, Ireland  
PHONE: (353)1-842 87 05  
FAX: (353)1-842 84 55

### ASIA

SHARP ELECTRONICS (SHANGHAI) CO., LTD.  
Microelectronics Sales & Marketing Division  
16F, King Tower, 28 Xin Jin Qiao Road,  
Pudong DIST, Shanghai 201206 P.R . China  
PHONE: (86)21-5854-7710/21-5834-6056  
FAX: (86)21-5854-4340/21-5834-6057

#### Registered Address

No. 11, De Bao Road, Xin Development BLDG  
46 Wai Gao Qiao Free Trade Zone, Shanghai  
200131, P.R . China

#### Beijing Office

Room 1062, Beijing Jing An Center No. 8 East  
Bei San Huan Road, Chao Yang DIST, Beijing  
100028 P.R . China  
PHONE: (86) 10-6466-7543/10-6466-6561  
FAX: (86) 10-6468-8920  
<http://sharp-world.com/products/devicechina/index.html>

#### SHARP-ROXY (HONG KONG) LTD.

Device Sales Division, 17/F, Admiralty Centre,  
Tower 1, 18 Harcourt Road, Hong Kong  
PHONE: (852)28229311  
FAX: (852)28660779  
<http://www.sharp.com.hk>

#### Shenzhen Representative Office

Room 13B1, Tower C, Electronics Science &  
Technology Building, Shen Nan Zhong Road,  
Shenzhen, P.R . China  
PHONE: (86)755-83273731  
FAX: (86)755-83273735

#### SHARP ELECTRONIC COMPONENTS (TAIWAN) CORPORATION

8F-A, No. 16, Sec. 4, Nanking E. R d., Taipei, Taiwan  
PHONE: (886)2-2577-7341  
FAX: (886)2-2577-7326/2-2577-7328

#### SHARP ELECTRONICS (SINGAPORE) PTE ., LTD.

396 Alexandra Road #07-00  
BP Tower Singapore 119954  
PHONE: (65) 62713566  
FAX: (65) 62713855  
<http://www.sesi-sharp.com>

#### SHARP MICROELECTRONICS TECHNOLOGY (M) SDN BHD.

Suite E 408, 4th Floor, East Tower,  
Wisma Consplant 1, No. 2 J In. SS 16/4,  
Subng Jaya, 47500, Selangor Darul Ehsan, Malaysia  
PHONE: (60) 3-5637-8964  
FAX: (60) 3-5638-4029

#### SHARP ELECTRONIC COMPONENTS (KOREA) CORPORATION

RM 501 iLsin B/D. 541, Dohwa-dong,  
Mapo-ku, Seoul, Korea, 121-701  
PHONE: (82)2-711-5813 ~ 8  
FAX: (82)2-711-5819

#### Distributed By